

## Mounting Information...

Reference guide for kit package containing brackets and fasteners for mounting the 4" ENC 150 encoder to the "Z" axis quill.

### Before proceeding:

- Please read the instructions and Reference Manual completely before beginning.
- Insure that the correct length encoder is being used for the total axis travel.
- Keep the reading head centered during installation.
- Clean the mounting surfaces.
- Save the alignment brackets with the Encoder Reference Manual after installation is completed.

## First Steps ...

### Machine

- ✓ Move the quill to its center of travel.
- ✓ Mark the axis so that it can be re-centered easily.

### Encoder

- ✓ Unpack encoder in a safe, convenient location.
- ✓ Do not remove the reading head alignment brackets until instructed.

## Center reading head ...

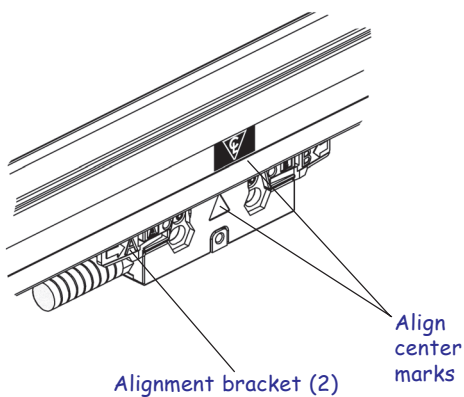

- Slide the reading head and brackets along the scale case until the center marks on the scale case and reading head are aligned.

## Cable exit ...

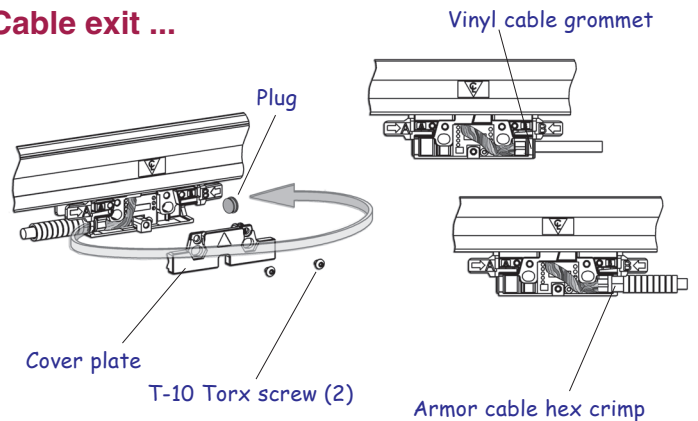

- Determine the cable exit direction before installing the encoder.
- To change the cable exit direction; remove the cover plate and rotate the cable 180°.

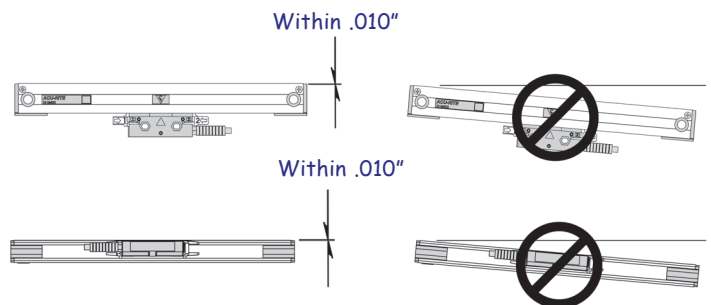

- Top surfaces to be aligned to within .010" to the axis travel.
- Front surfaces to be aligned to within .010 to the axis travel.

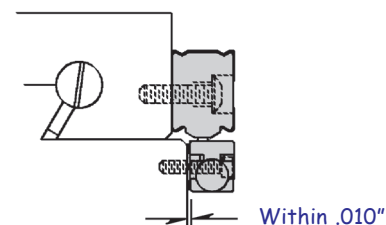

- Reading head must be aligned mounted parallel with the scale case to within .005". Alignment brackets will provide correct alignment of the reading head to the scale case.

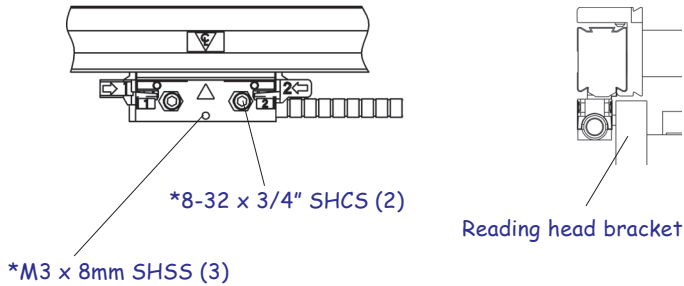

- Insert the leveling screws, and set each by placing a .001" - .003" feeler gage between the set screw and the bracket.
- Adjust each set screw until a slight drag is felt on the feeler gage.
- **Evenly tighten** the two \*8-32 x 3/4" SHCS.

### Encoder button up ...

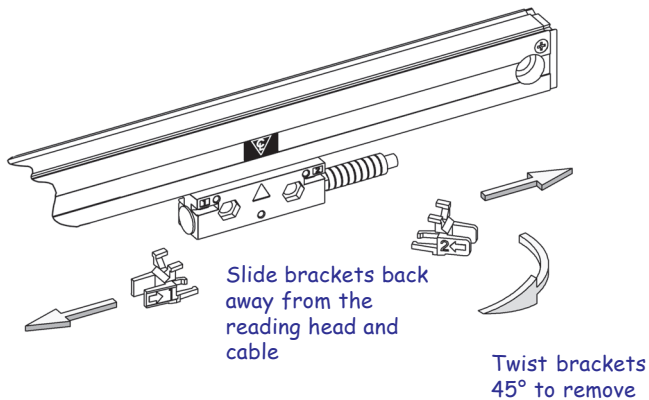

- Use allen wrench from set screw adjustment to slide alignment brackets away from the reading head.
- Remove alignment brackets and save.
- Move the axis through its full travel. Confirm that the assembly does not interfere with the machine movement.

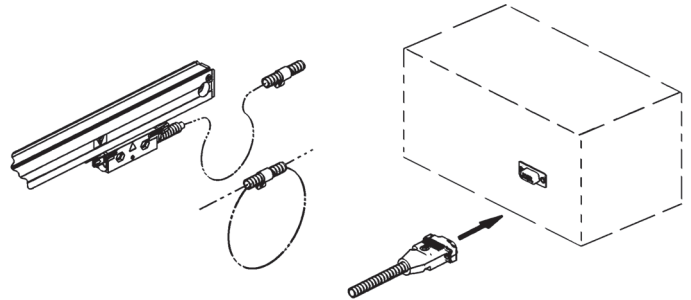

- With the longitudinal axis installation complete, route the cables providing sufficient slack loops for machine movement to the readout.
- Secure cables by fastening with clips or ties.
- Attach the linear encoder connectors to the readout.
- Complete the installation by following the steps in "Checking Your Installation" section in the encoder "Reference Manual".